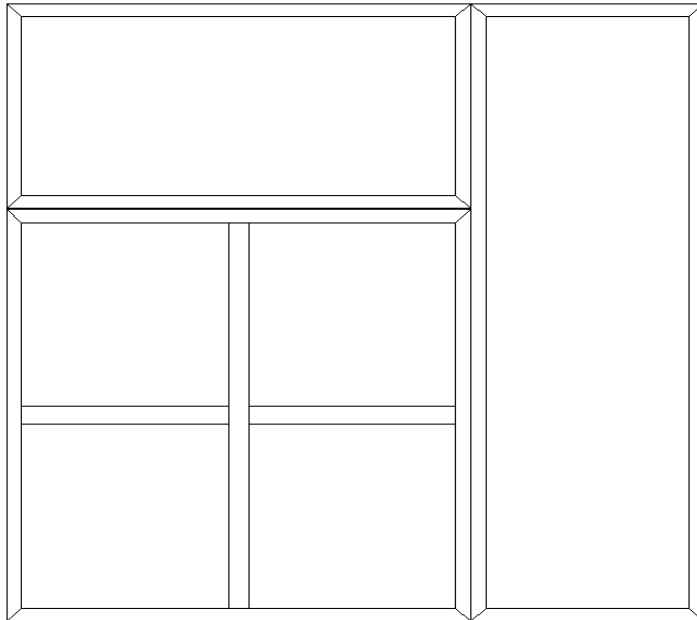

---

**INSTALLATION MANUAL – FIXED STOREFRONT OPENINGS**

FO

---

**SYSTEM DESCRIPTION**

- Extruded and filled aluminum framing, tested and approved by European NB - institutes.
- 85 mm frame depth
- Clear, fire-rated safety glazing

**REQUIRED TOOLS**

- 12mm open wrench
- Power drill with 4, 7 drills
- Heavy-duty glass handling tools
- Non-metal hand wedges
- Gasket roller
- C-clamps
- Knife
- Tape measure
- Level
- Rubber mallet

**REQUIRED MATERIALS**

- Mineral wool insulating material
- Silicone caulking
- 7,5 mm x 72 / 100 mm zinc-coated flat head sheet metal screws / concrete screws

**TABLE OF CONTENTS**

General Installation Notes	Page 3
Installation	Page 5
Determine Frame Reference Point	Page 5
Unpack Frame	Page 5
Multiple Frames	Page 5
Installation of Frame	Page 5
Prepare for Glazing	Page 6
Glazing	Page 6
Finishing	Page 7
Figure: Typical Frame-to-Frame Joint Detail	Page 8
Figure: Typical Perimeter Detail	Page 9

---

## GENERAL INSTALLATION NOTES

1. Do not drop, roll or drag boxes of aluminum framing. Move and stack boxes with proper support to prevent distortion. If forklifts are used, be especially careful about striking the boxes when lifting or moving.
2. Store in a dry, out of the way area. If rain exposure, condensation or any water contact is likely, then all packaging material should be removed. Wet packaging materials will discolor and may stain aluminum finishes and paints.
3. All materials should be checked for quantity and quality upon receipt. Aluflam must be contacted immediately of any discrepancies in shipment. Check to make sure that you have the required supplies and tools necessary for the installation.
4. Carefully check the openings and surrounding construction that will receive your material. Remember, if the construction is not per the construction documents, it is your responsibility to notify the general contractor in writing. Any discrepancies must be brought to the general contractor's attention before you proceed with the installation.
5. Collect your shop drawings, materials, packing list, and this installation manual. Carefully review parts location, the sequence of installation, when you glaze it, and how you seal it. Installation instructions are of a general nature and may not address every condition you will encounter. The shop drawings were prepared specifically for the project.
6. Any material substitutions must be of equal or greater quality. Consult Aluflam prior to substituting any material to ensure that the products' fire ratings are not violated.
7. Remember to isolate, in an approved manner, all aluminum from uncured masonry or other incompatible materials.
8. System-to-structure fasteners are not supplied by Aluflam. Fasteners called out on shop drawings are to indicate minimum sizes.
9. If any questions arise concerning Aluflam products or their installation, contact Aluflam for clarification before proceeding.
10. Aluflam product installation is frequently completed before drywall, flooring and other products. Take the extra time to wrap and protect the installed material.
11. Cutting tolerances are  $\pm 0,8$  mm unless otherwise specified.
12. Aluflam framing products are prefinished and prefabricated, and must be protected against damage.
13. Concrete, mortar, plaster, muriatic acid and other alkaline and acid based construction and cleaning materials may be very harmful to frame finishes and should be removed with water and mild soap immediately or permanent damage or staining of the finishes may occur. A spot test is recommended before any cleaning agent is used, and abrasive type cleaners must never be used.

14. Frames are never to be used as ladders, step stools, scaffolds or scaffold supports.

15. All work must start from, and be referenced to benchmarks, offset lines and/or column centerlines established by the architectural drawings and the general contractor.

16. All frames must be installed plumb, square, level and true, and in accordance with approved shop drawings.

17. Glass and glazing building codes governing the design and use of products vary widely. Aluflam A/S does not control the selection of the products, product configurations, operating hardware and function, or glazing materials, and Aluflam assumes no responsibility for these design considerations. It is the responsibility of the design professional, owner, architect, specifier, general contractor, and the installer to make these selections in strict accordance with all applicable codes.

## INSTALLATION

### STEP 1 DETERMINE FRAME REFERENCE POINT

Establish the frame reference lines or the exterior/interior plane of the frames to be installed using either bench marks, offset lines, or column centerlines provided by the general contractor and referenced on the shop drawings. Use the established reference points to determine the installation points for each frame opening at the head, and jambs.

### STEP 2 UNPACK FRAME

- a) Remove loose components, such as glazing beads, intumescent strips, seals, etc, and set aside in a well protected area.
- b) Carefully lift frame out of packaging. At this point, the frame joints are unprotected. Handle the frame with extreme care to avoid separation of corner joints.

### STEP 3 MULTIPLE FRAMES

- a) In the case of attached, multiple frames – assemble the frames prior to installing into the wall opening. See Figure: Typical Frame-to-Frame Joint Detail.
- b) Lay out all frames to be attached on a smooth, dry surface. Ensure that frames are well protected from abrasion and impact. Strips of wood are very suitable for this purpose.
- c) Insert frame splines (2 per joint) into narrow groove on outside edge of frame to be joined. Splines may be lubricated with liquid soap for ease of insertion. Assure that frames line up length-wise and secure using c-clamps.
- d) Anchor joints through factory pre-drilled holes.

### STEP 4 INSTALLATION OF FRAME

- a) Install the frame plumb, square, level and true.
- b) Gradually and evenly back out all adjustment screws with 12 mm open wrench (see detail). Be careful to not cause frame distortion due to excessive adjustment.
- c) Measure the size of the frame and ensure that it meets the dimensions referenced on the shop drawing.

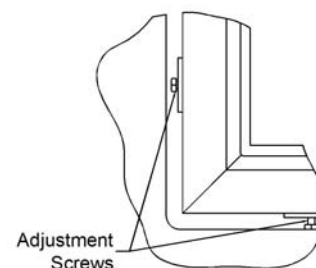

- d) Drill anchor locations into surrounding structure using the factory pre-drilled frame holes as guides. Use 4, 7 mm drill.
- e) Anchor the frame to the wall opening at all pre-drilled anchor locations.
- f) Ensure that frame dimensions have not changed.

## **STEP 5 PREPARE FOR GLAZING**

- a) Inspect the factory installed intumescent glazing tape in the frame opening and make sure it hasn't shifted during installation.
- b) Place setting blocks on top of steel angle brackets at location 1 and 2.

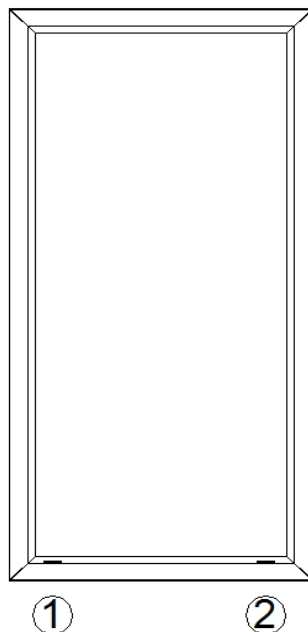

## **STEP 6 GLAZING**

The Swissflam and Contraflam glass products that are used in Aluflam frame systems are heavy and fragile. Make sure that proper tools and lifting capacity is available prior to opening glass crate.

Avoid impact with any metal objects and avoid setting the glass down directly onto floor. Use wood strips or other suitable material for setting down the glass section prior to installation.

For full instructions on handling and installing glass, please refer to Vetrotech Saint-Gobain's installation instructions.

- a) Center the glass in the frame and carefully set the unit down onto the setting blocks at location 1 and 2.
- b) While supporting glass in place, secure it by manually bending stainless steel glazing clips. See illustration below. **(DO NOT USE METAL TOOLS)**
- c) Snap in glazing beads on all four sides. If necessary, use mallet or other nonmetal tool to force glazing beads into place.
- d) Install glazing gaskets.

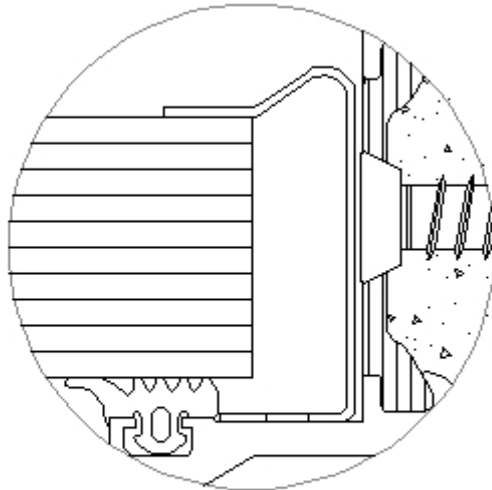

YES

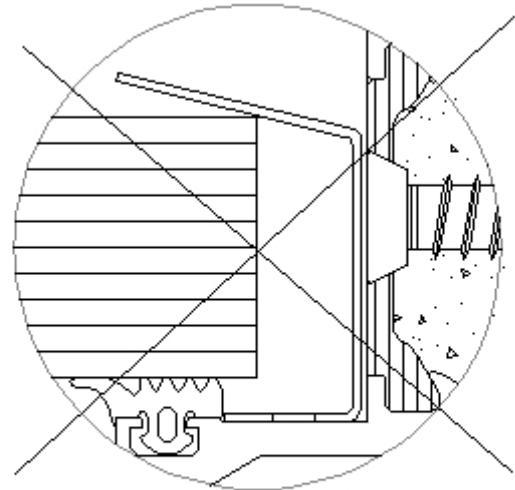

NO

## STEP 7 FINISHING

- a) Fill gaps around frame with mineral wool insulating material. Pack as tightly as possible.
- b) Finish gaps by applying a continuous bead of silicone caulking.
- c) Clean glass units using mild glass cleaner. For further information, refer to Vetrotech's glass cleaning and maintenance instructions.

## TYPICAL FRAME-TO-FRAME JOINT DETAIL Aluflam Storefront Frame Assembly

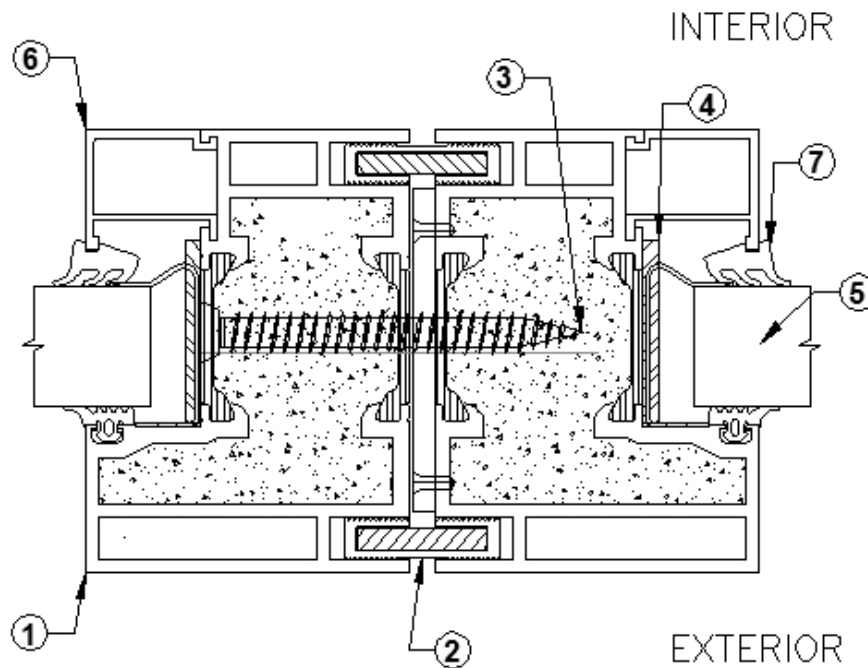

### NOTES

1. Filled aluminium 62x 85 mm frame - factory assembled
2. Aluminium frame splines - furnished by Aluflam
3. Flat head sheet metal / concrete screws- 7,5x 72mm
4. Intumescent glazing tape – factory installed
5. Glazing - furnished by Aluflam
6. Glazing bead - furnished by Aluflam
7. Glazing gasket - furnished by Aluflam

## TYPICAL PERIMETER DETAIL Aluflam Storefront Frame Assembly

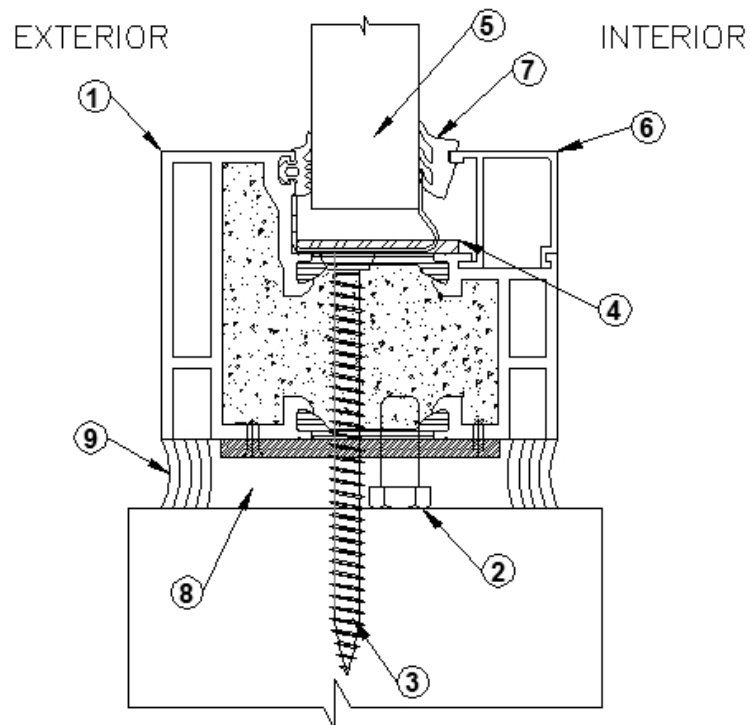

### NOTES

1. Filled aluminium 62x 85 mm frame - factory assembled
2. Aluminium frame splines - furnished by Aluflam
3. Flat head sheet metal / concrete screws- 7,5x 72mm
4. Intumescent glazing tape – factory installed
5. Glazing - furnished by Aluflam
6. Glazing bead - furnished by Aluflam
7. Glazing gasket - furnished by Aluflam
8. Mineral wool insulation, well packed - not by Aluflam
9. Silicon caulking - not by Aluflam